

SECTIUNE DE CAPAT C-C / C-C BEARING SECTION  
Sc. 1:20

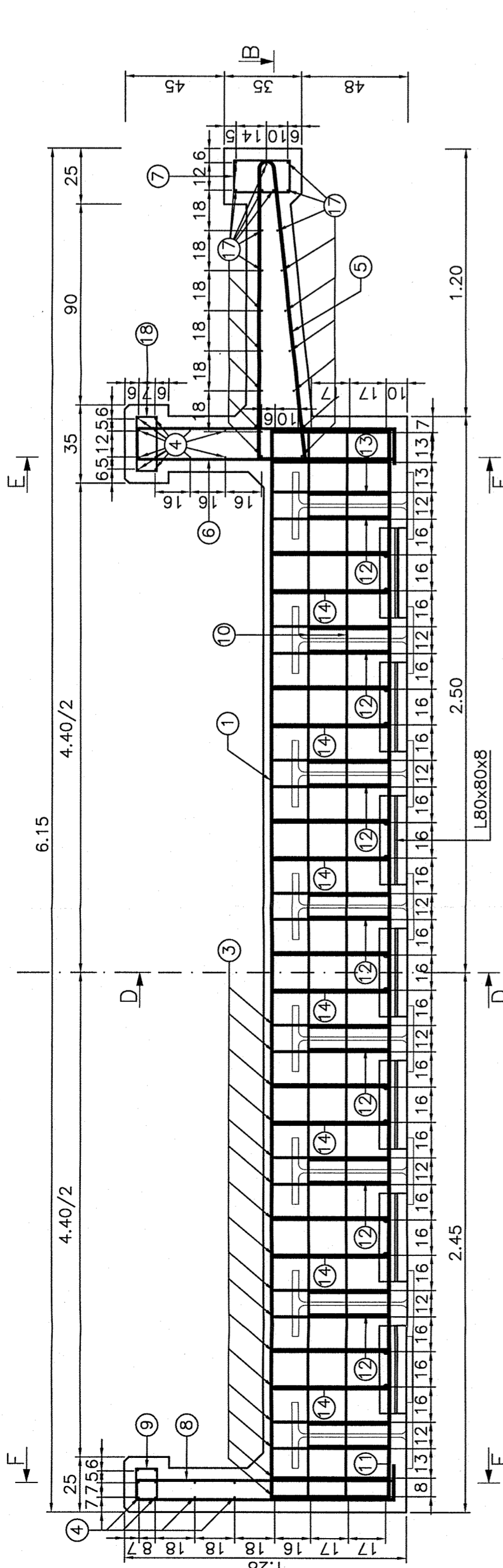

SECTIUNE IN CAMP A-A / A-A SECTION BETWEEN BEARINGS  
Sc. 1:20

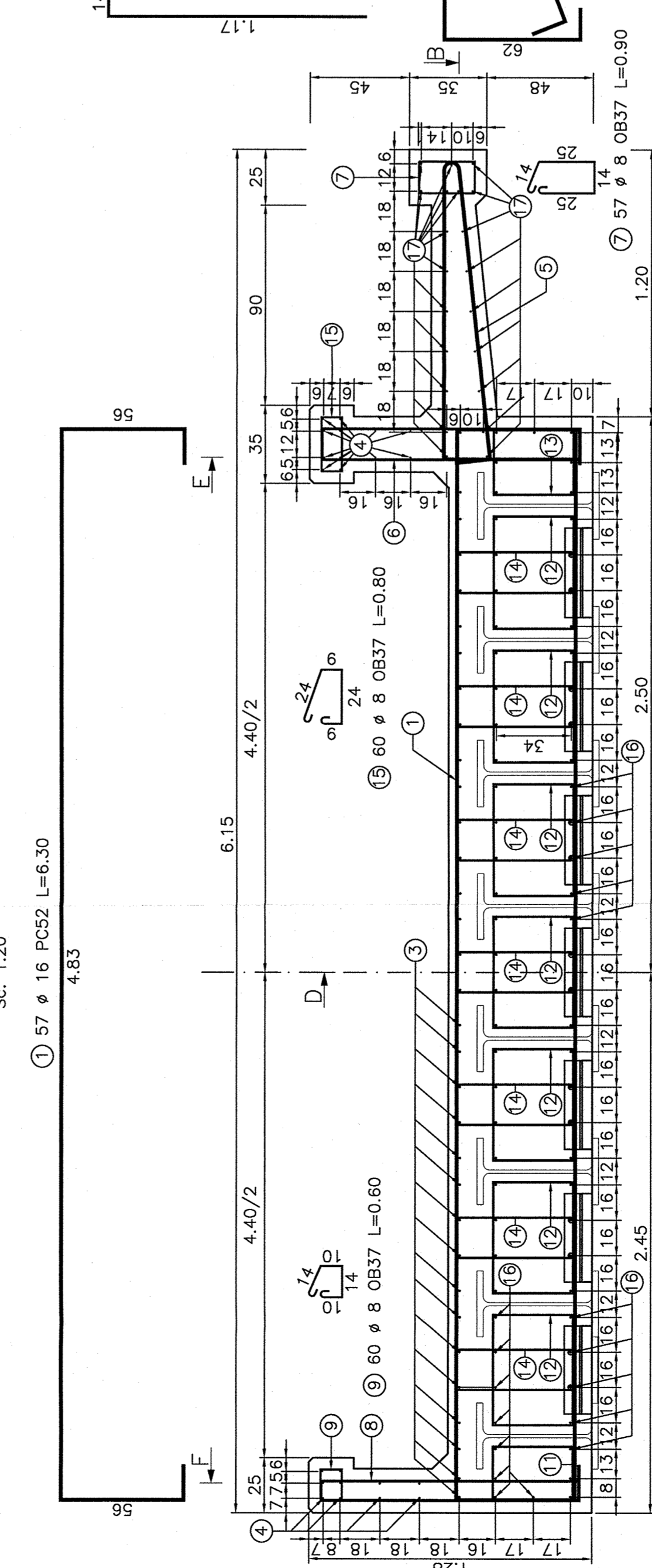

SECTIUNE D-D / D-D SECTION  
Sc. 1:20

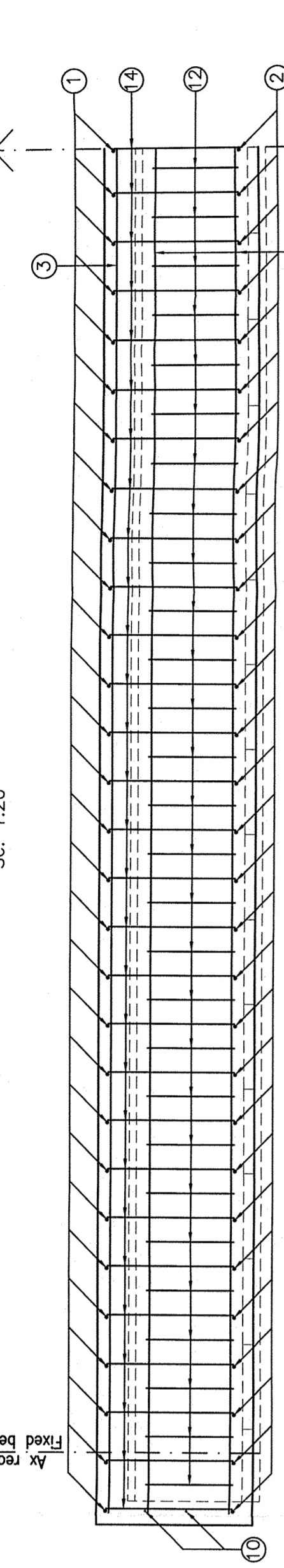

SECTIUNE E-E / E-E SECTION  
Sc. 1:20

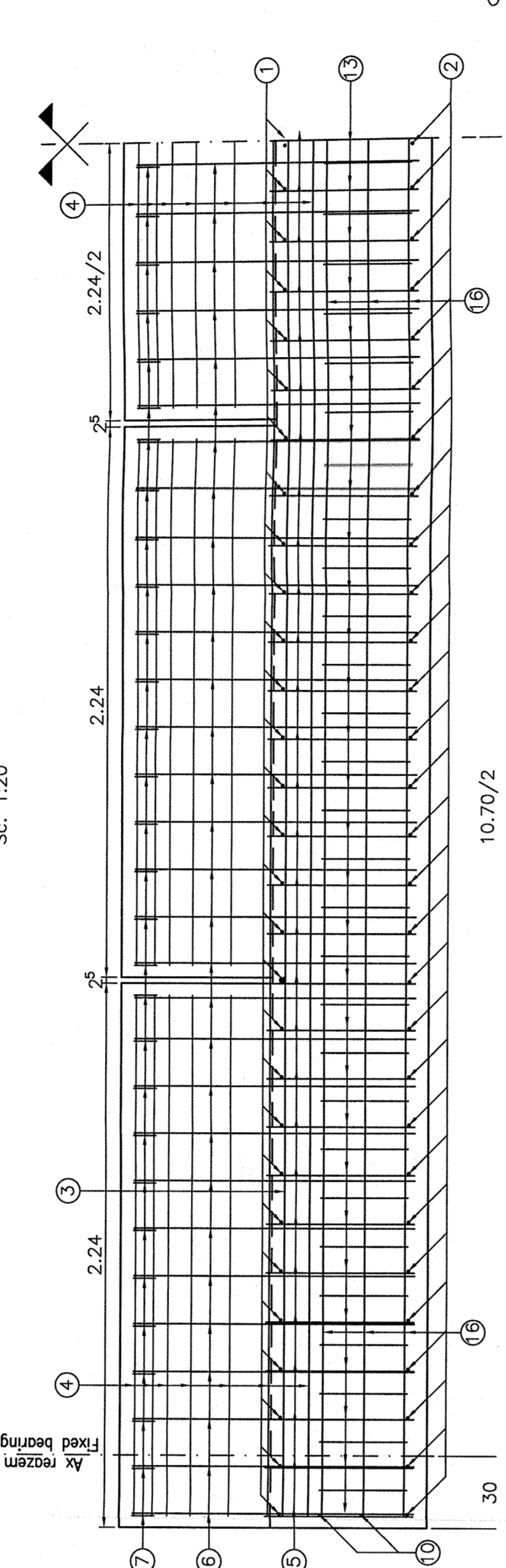

SECTIUNE F-F / F-F SECTION  
Sc. 1:20

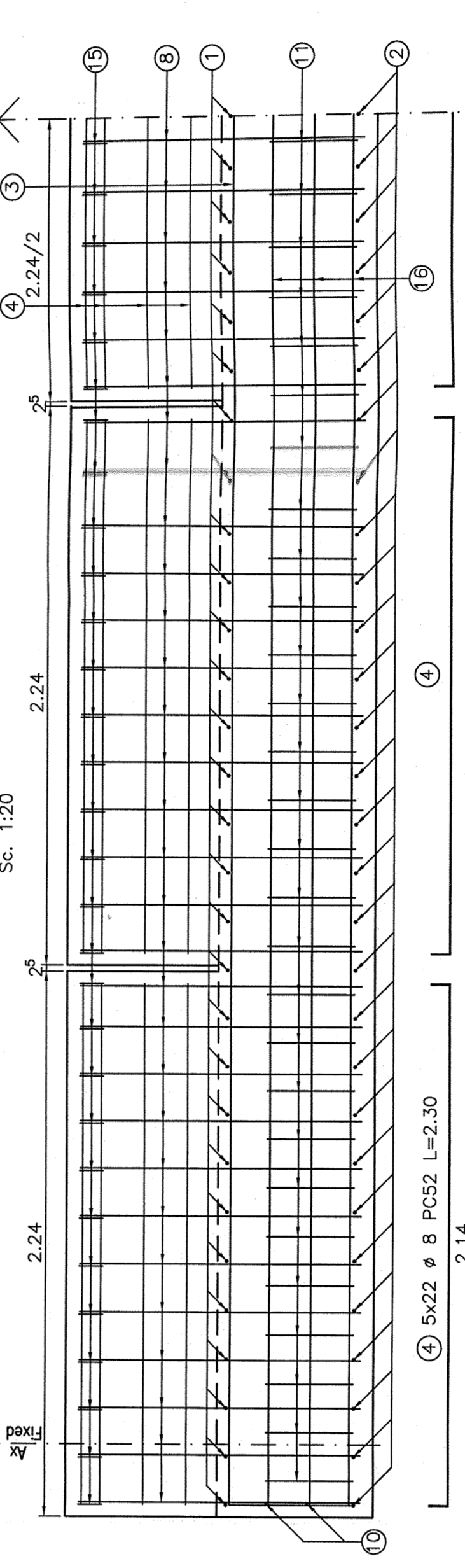

① 56  $\phi$  10 OB37 L=1.65  
② 57  $\phi$  16 PC52 L=5.15  
③ 7x56  $\phi$  10 OB37 L=1.90  
④ 7x57  $\phi$  10 OB37 L=1.60  
⑤ 56  $\phi$  10 OB37 L=1.45  
⑥ 57  $\phi$  16 PC52 L=2.45  
⑦ 57  $\phi$  8 OB37 L=0.90  
⑧ 70  $\phi$  12 PC52 L=11.45  
⑨ 34  $\phi$  12 PC52 L=12.30  
11.20/2  
2.45  
2.50  
1.20  
10.70/2  
11.20/2

EXTRAS DE ARMATURA

Marca	$\phi$ (mm)	n (buc.)	L (m)	OB37	PC52
1	16	57	6.30	$\phi$ 8	$\phi$ 10
2	16	57	5.15		$\phi$ 12
3	12	34	12.30		418.20
4	8	110	2.30		253.00
5	16	57	3.65		208.05
6	12	60	2.50		150.00
7	8	60	0.90		54.00
8	12	60	2.45		147.00
9	8	60	0.60		36.00
10	10	4	5.05		20.20
11	10	56	1.64	91.84	
12	10	392	1.90	744.80	
13	10	56	1.45	81.20	
14	10	399	1.60	638.40	
15	10	60	0.80	48.00	
16	10	70	11.45	801.50	
17	10	21	11.40	239.40	
<b>TOTAL LUNGIMI PE DIAMETRU (m)</b>				90.00	2405.74
<b>GREUTATE PE METRU (kg/m)</b>				0.395	0.617
<b>GREUTATE PE TIP METRU (kg)</b>				35.51	1483.23
<b>GREUTATE PE TIP OTEL (kg)</b>				1519.00	2254.00
<b>GREUTATE TOTALA (kg)</b>				3773.00	

DALA PREFABRICATA  
SELF-SUPPORTING SLAB

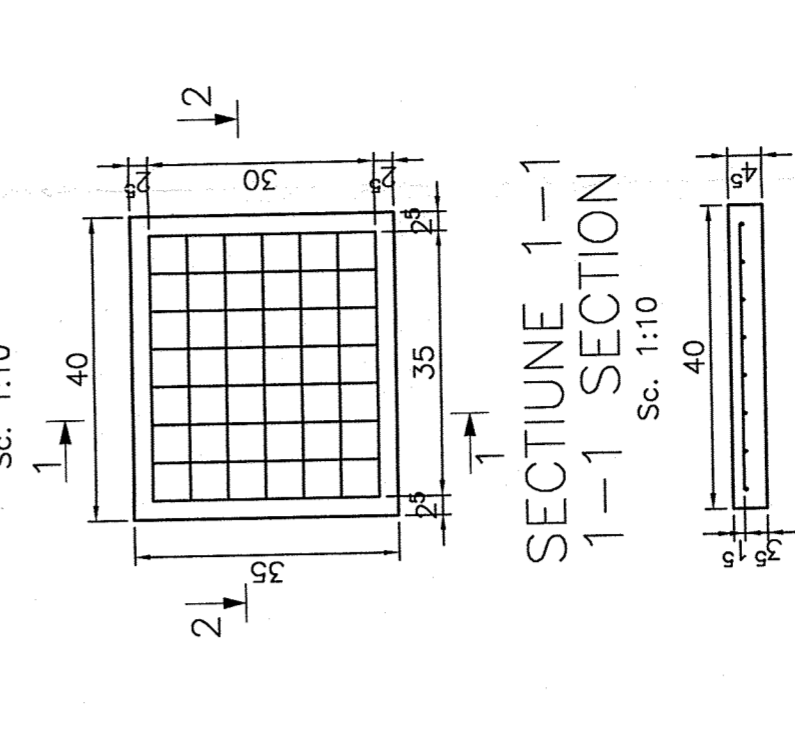

ARMATURA:  
PC52  
OB37  
ACOPERIRE: 5cm,3cm  
REINFORCEMENT:  
PC52  
OB37  
COVERING: 5cm,3cm



Plasa sudata S490(STNB)/Welded net S490(STNB)  
8x50-350x300 (Buc=1)  
Gbu=1350x700-6x10-395=1.92kg  
Gtotal=32x7x8Buc=32x7x1.92=430.08kg

ROMANIAN RAILWAY NATIONAL COMPANY  
 prontec  
 POS Transport  
 Date: 10.05.2008  
 Desena: Ing. Liviu Bucur  
 Verificat: Ing. Bogdan Stancu  
 Proiectat: Ing. Stelian Vira-Oros  
 Date / Date: 10.05.2008  
 Desena / Drawn: Ing. Liviu Bucur  
 Verificat / Checked: Ing. Bogdan Stancu  
 Proiectat / Projected: Ing. Stelian Vira-Oros  
 Date / Date: 10.05.2008  
 Desena / Drawn: Ing. Liviu Bucur  
 Verificat / Checked: Ing. Bogdan Stancu  
 Proiectat / Projected: Ing. Stelian Vira-Oros